

Contents

Contents.....	1
1. Product description.....	2
1.1 Host structure.....	2
1.2 5D Four-wheel alignment system installation method.....	5
1.2.1 Target selection.....	6
2. Preparations before wheel alignment operation.....	7
2.1 Preparation before operation:.....	7
2.2 Fixture/target installation.....	8
2.3 Device connection.....	10
3. 5D Four-wheel alignment system operation process.....	12
4. Start measurement.....	13
4.1 Host on/off and function menu main interface.....	13
4.2 Target monitoring.....	13
4.3 Measurement modes.....	14
4.3.1 Ground mode.....	15
4.3.2 Lift mode.....	20
4.4 Back tilt measurement.....	27
4.5 Vehicle adjustment.....	30
4.6 Data saving.....	31
4.7 Print report.....	32
5. System setting.....	33
5.1 Advanced setting.....	34
5.1.1 Target type setting.....	35
5.1.2 Set the front position.....	37
5.1.3 Set camera parameters.....	38
6. Update the model library.....	39

1. Product description

FCAR 5D four wheel aligner is the first 5D aligner product and platform of FCAR, combined with the application feedback of 3D aligner users and the lack of 3D products. (field, precision, transportation, installation, shunting, etc.) Through more than 5 years of research and development and test verification, it has launched an era-based, landmark four-wheel aligner product. Since then, the four-wheel aligner has achieved a leap from the 3D era to the 5D era.

1.1 Host structure

FCAR 5D four-wheel alignment system supports a variety of matching configurations, and users can customize according to their own needs.



Technical parameter:

Measure item	Measure accuracy	Measure range
Camber angle	$\pm 0.01^\circ$	$\pm 8^\circ$
Caster angle	$\pm 0.03^\circ$	$\pm 19^\circ$
Front wheel inclination angle	$\pm 0.02^\circ$	$\pm 19^\circ$
Toe	$\pm 0.01^\circ$	$\pm 2^\circ$
Rear wheel thrust angle	$\pm 0.02^\circ$	$\pm 2^\circ$

Rear wheel axle deflection	$\pm 0.02^\circ$	$\pm 2^\circ$
Wheelbase difference	$\pm 0.02^\circ$	$\pm 2^\circ$
Front set back	$\pm 0.02^\circ$	$\pm 2^\circ$
Rear set back	$\pm 0.02^\circ$	$\pm 2^\circ$

Tablet structure diagram

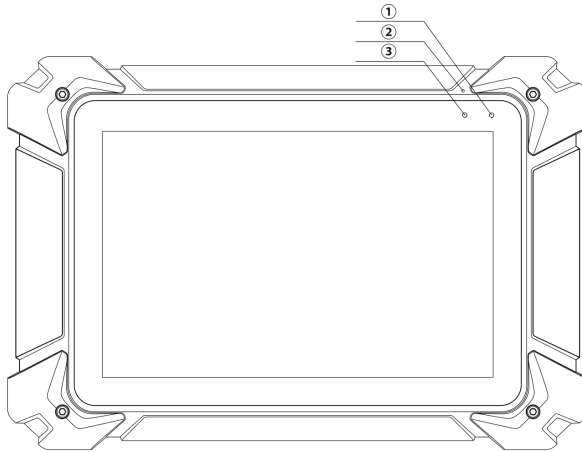

Serial number	Name	Description
①	Power Indicator	Charging indicator
②	Microphone port	Voice input
③	Light sensor	External light intensity sensing

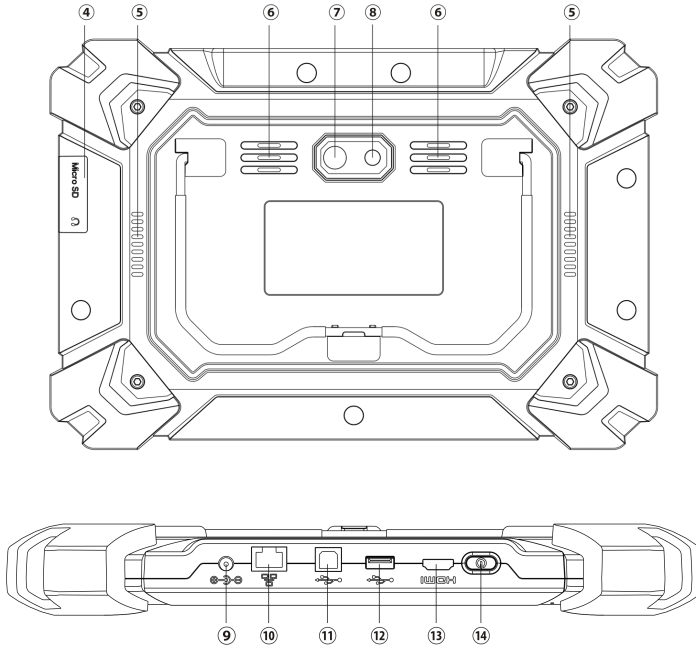

Serial number	Name	Description
④	TF card slot / 3.5 headphone hole	Storage TF card location / headphone hole
⑤	Heat dissipation hole	For tablet cooling, avoid overheating
⑥	External horn hole	For external sound playback
⑦	Camera	For photography or video recording
⑧	Flash lamp	Used to provide light when light is weak
⑨	DC power port	For tablet charging or power supply
⑩	RJ45 interface	For network connection
⑪	USB interface (B shape)	Device interface: used to connect computers and use tablets as USB drives

⑫	USB interface	Host interface: for tablets to connect to other devices or to connect to USB drives
⑬	HDMI interface	Standard HDMI interface: used to connect HDTV output
⑭	Power switch	For on / off tablets, or for locking screens

1.2 5D Four-wheel alignment system installation method

FCAR 5D four-wheel alignment system breaks through the limits of the field and is suitable for a variety of lifting platforms (two columns, four columns, small scissor and large scissors). The following are installation options:

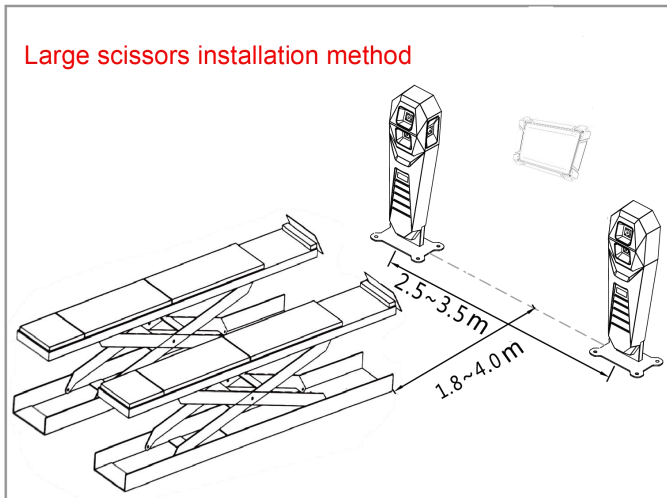

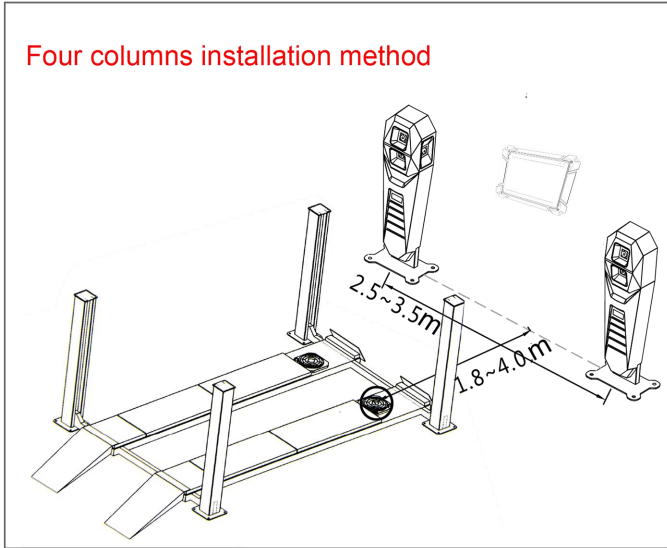
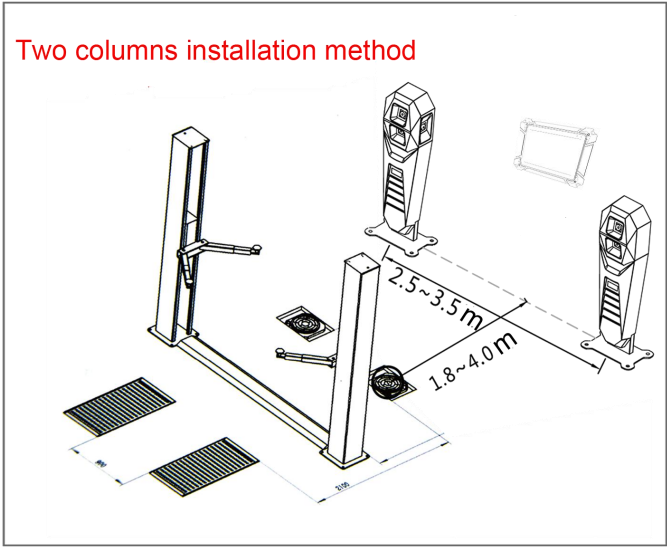

Note: The small scissor installation scheme is similar to the large scissor



1.2.1 Target selection

Please refer to the table below to select the target type according to different lifting platforms:

Type	Physical view	Adaptation plan
Long target		large scissor/small scissor installation plan
Trapezoidal target		Two columns installation plan , four columns installation plan

Tip: the target type selection is complete and must be set in [Advanced Settings], as shown in Chapter 6.

2. Preparations before wheel alignment operation

2.1 Preparation before operation:

- 1) Install the corner plate and lock the corner plate with the locking pin to prevent it from rotating;
- 2) When driving the car, ensure that the tire is at the center of the corner plate. After stopping the car, tighten the handbrake to ensure that the car does not move and the personnel are safe;
- 3) When car pushing compensated and adjusted, please ensure the horizontal position of the steering wheel and use the steering wheel holder to lock it, as shown in the figure. When measuring and adjusting the caster measurement, pull the handbrake and hold the foot brake.

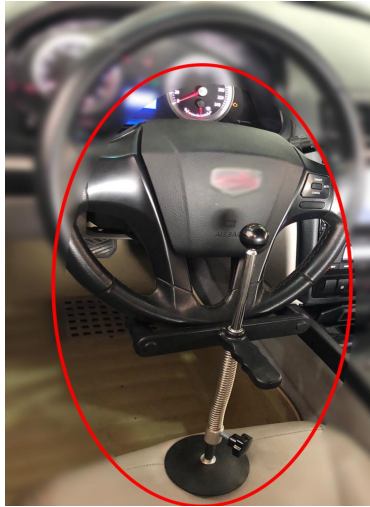

Figure 2.1-1 Steering wheel holder installation

2.2 Fixture/target installation

FCAR 5D four-wheel alignment system is equipped with 4 fixtures, 4 targets and 2 hosts. The host must be installed in the front position of the head of vehicle in the left and right direction (refer to the 5D four-wheel alignment installation method). The front wheel should install two short rod targets separately and the rear wheel should install two long rod targets separately.

➤ How to install fixture/target

The fixture has been locked to the center position before leaving the factory. There is no need to adjust the center and the fixture installation steps are as follows:

- 1) Rotate the hand wheel to make the claws fit to the diameter of the rim. The installation direction of the clamp is shown in figure 3.2-1;
- 2) The clamp handle is up and perpendicular to the ground, and the four jaws should stay to the edge of the rim closely;

- 3) Rotate the hand wheel again to adjust and lock the clamp to the rim position.

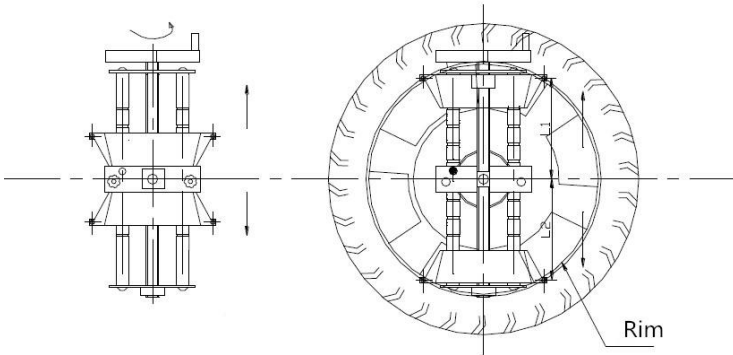
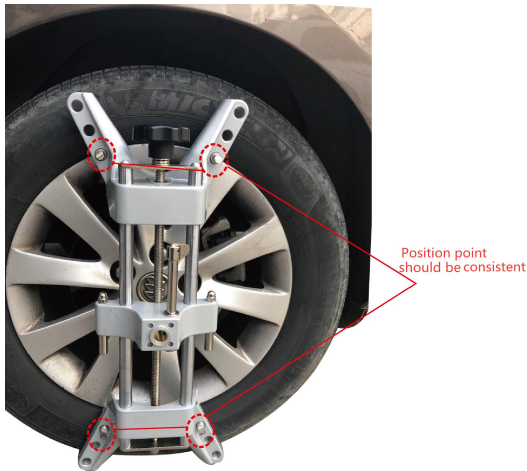

Figure 3.2-1 Fixture installation

The physical photo is shown below:



Note: When assembling the fixture, the claws should keep away from the lead block on the rim, please make sure that the four claws are in full contact with the rim.

Installed long and short target object as shown below:



2.3 Device connection

The interfaces on the back of the main unit are as shown below:

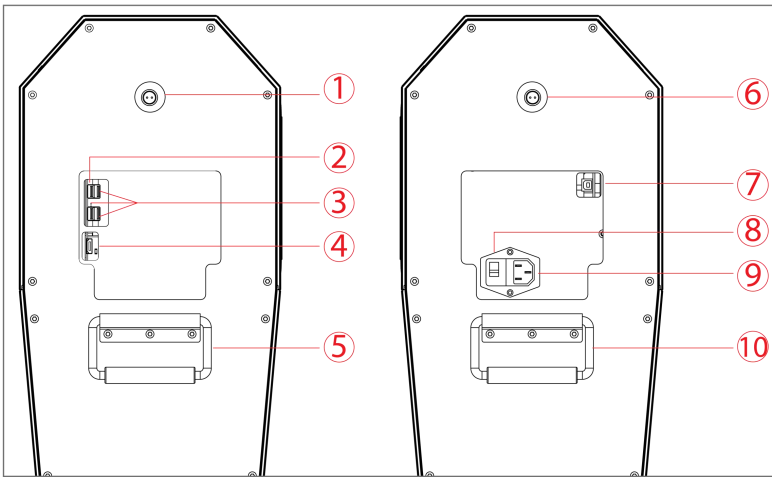

Serial number	Name	Serial number	Name
①	Power interface	②	Softdog
③	USB interface	④	HDMI HD output
⑤	Handgrip	⑥	Power interface
⑦	USB interface (B shape)	⑧	Power switch
⑨	Power interface	⑩	Handgrip

Connect the two mainframes with the power cord and data cable of our factory configuration as shown below. Connect the power plug to the standard three-terminal power socket. The power supply requires 220V. Turn on the power switch to start the two hosts.

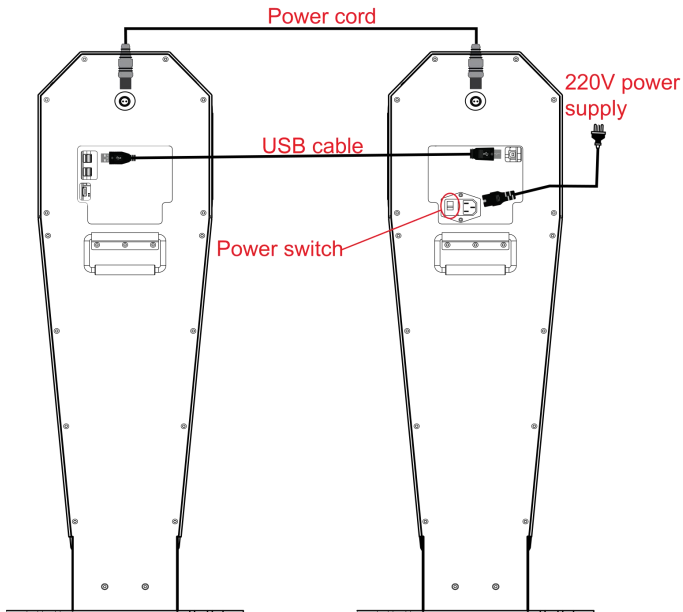

3. 5D Four-wheel alignment system operation process

The flow chart is as follows:

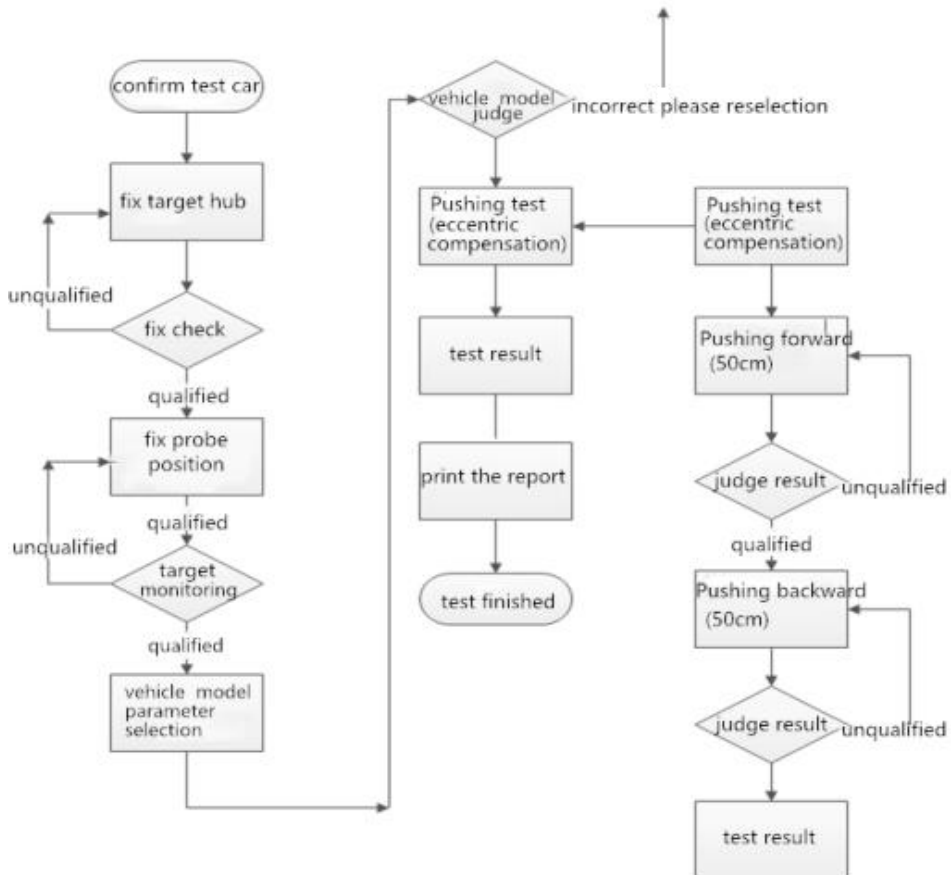

4. Start measurement

4.1 Host on/off and function menu main interface

Turn on the tablet power and connect to the wireless WIFI (SSID: 18X5D**** , password :11111111) , operate the program, the main function menu is shown as figure 4.1-1:

Note: How to connect, please confirm whether the host is started, whether the network is connected smoothly, or confirm that the server IP address is correct (default address: 192.168.100.4)

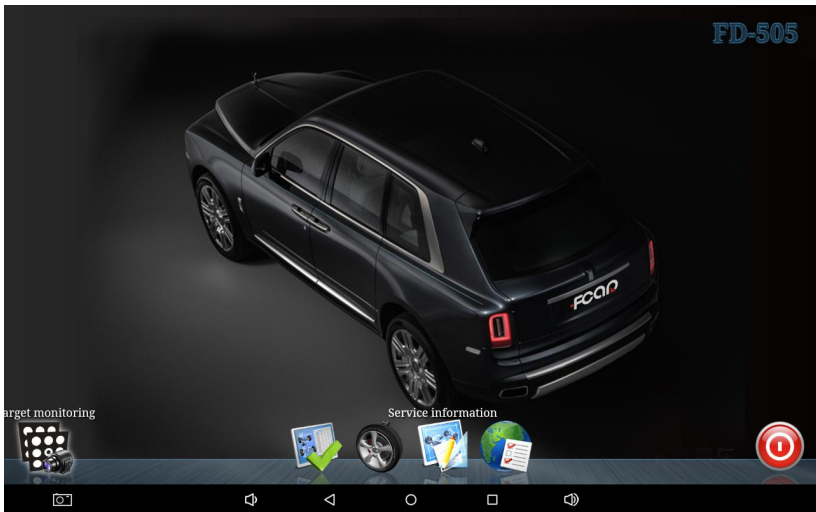



Figure 4.1-1 system main interface

4.2 Target monitoring

Before performing four-wheel positioning, no matter which measurement mode is used, target monitoring is required first. Select Target Monitoring 【】 on the main interface of the system, as shown in figure 4.2-1 and 4.2-2, to ensure that all four targets are clearly within the visible range of the camera.

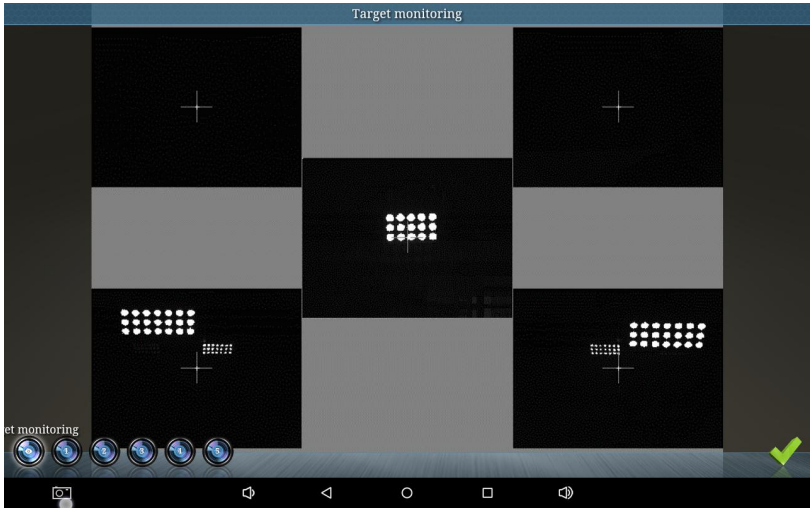

Figure 4.2-1 camera monitoring

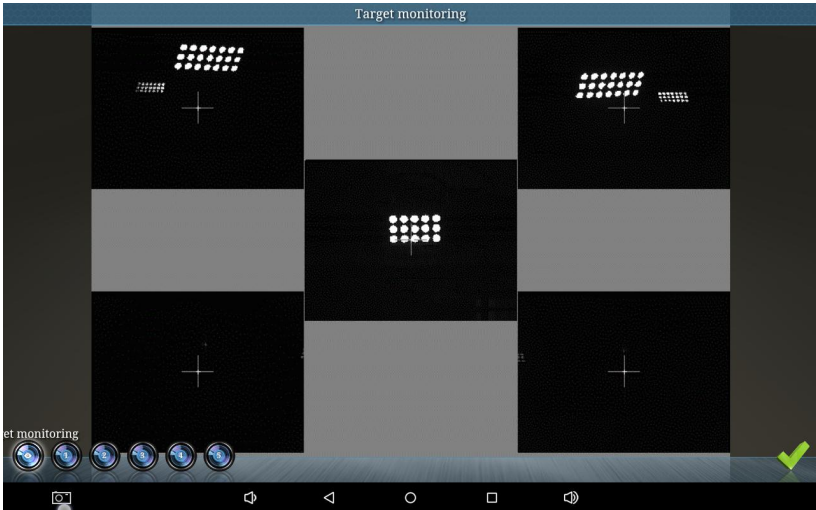

Figure 4.2-2 Target monitoring and lifting mode

4.3 Measurement modes

The two measurement modes of the FCAR 5D four wheel aligner: ground mode and

lift mode to meet different measurement platforms or site limits for users. The following two measurement modes are introduced separately.

4.3.1 Ground mode

General measurement flow of ground mode: Model selection→ Push compensation →adjust→ Back tilt measurement→ adjust→ Test drive→ Save measurement data →View/print results , the operation flow and method of general measurement will be described below.

Vehicle selection



Select **【**  **】** on the main interface of the system, the system will automatically enter the vehicle selection interface. The vehicle selection interface is shown in figure 4.3.1-1:



Figure 4.3.1-1 Vehicle selection

Vehicle pushing compensation

After finding the model to be tested, click **【✔】** to automatically enter the pushing compensation measurement interface. If the target positioning is not accurate, there will be corresponding adjustment prompts, as shown in figure 4.3.1-2, or other prompt information, Adjust the target respectively, until the prompt disappears.

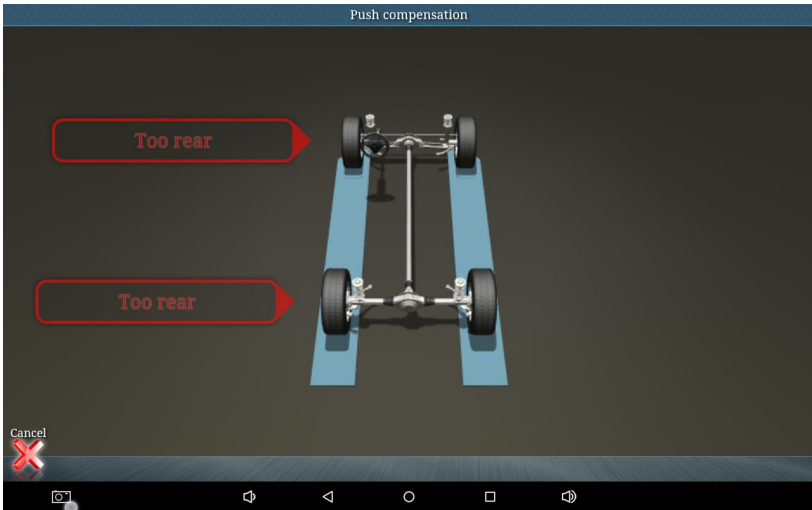

Figure 4.3.1-2 Target adjustment prompt

After the adjustment is completed, the program automatically enters the car pushing interface, as shown in figure 4.3.1-3.

➤ How to perform vehicle pushing compensation

- 1) According to the pushing prompt, drive the car slowly and evenly backwards about 15CM (the steering wheel is centered);

Note: Before pushing the car, you must ensure that the steering wheel is horizontal and lock it with the steering wheel mount.

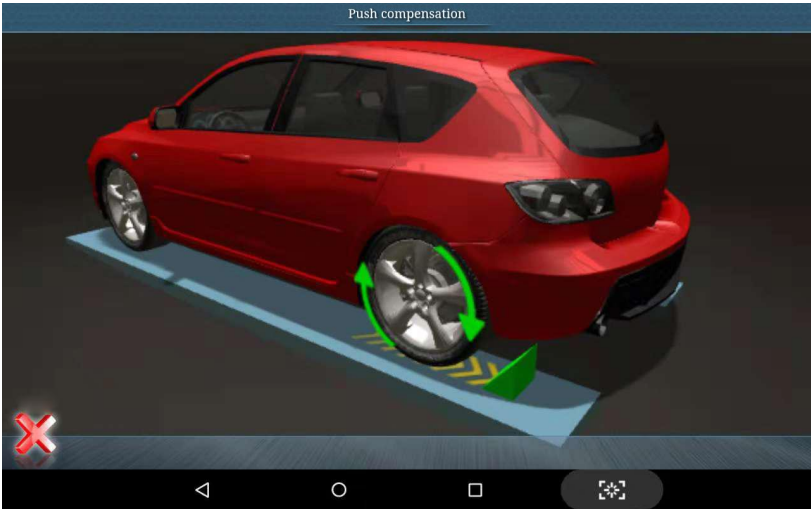

Figure 4.3.1-3 Forward pushing

- 2) When the following interface is prompted, please stop pushing backward, and the rubber pad can be used to stuck the wheel;

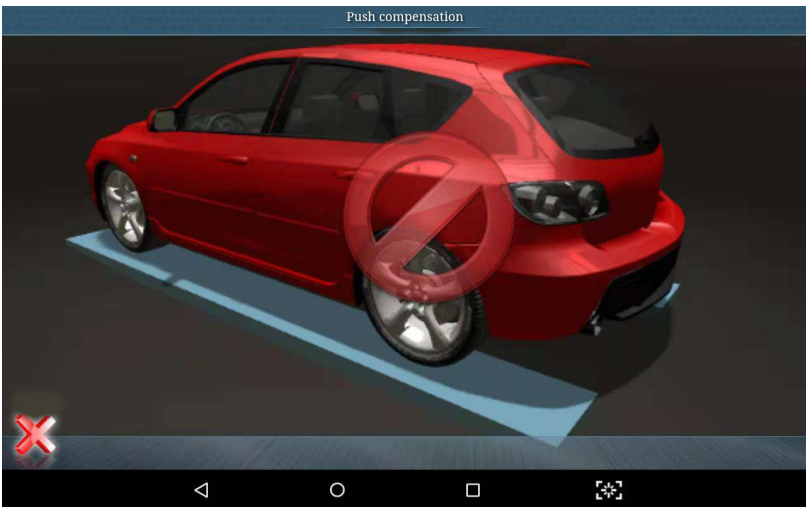

Figure 4.3.1-4 Stop pushing

- 3) When the following interface is prompted, move slowly and evenly forward

according to the screen prompts;



Figure 4.3.1-5 Forward pushing

- 4) When the following interface is prompted, stop pushing forward. At this time, the system may take a few seconds to calculate, please wait;

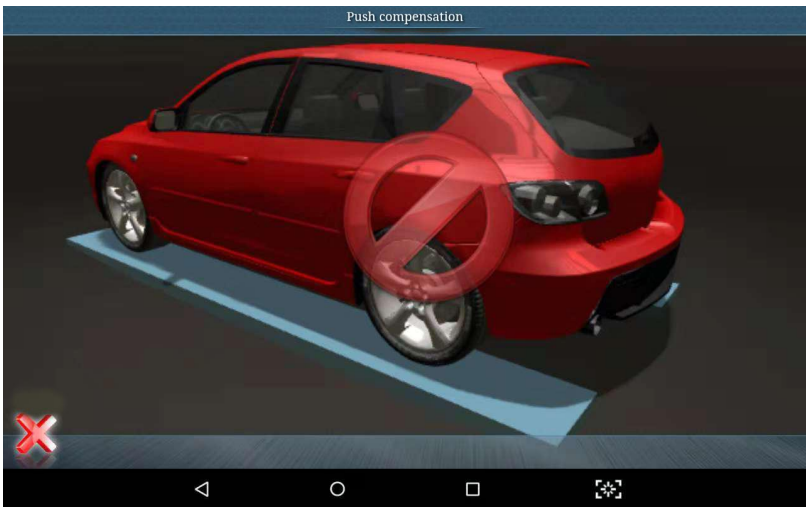

Figure 4.3.1-6 Stop pushing

- 5) If the measurement is successful, the system will automatically jump to the
18

measurement result interface, as shown in figure 4.3.1-7 (The measurement data of the figure is only for operation instructions, and does not have any reference value).



Figure 4.3.1-7 Measurement result

In order to help the user understand the vehicle's better condition, the result display interface uses different color fonts to indicate whether the current measured value is within the standard range:

Red font: measured value beyond the standard range

Green font: measured value within the standard range

White font: current measured value without reference range

Precautions: Before measuring, be sure to center the steering wheel and fix it so that the steering wheel does not rotate during the pushing process, which will affect the test results.

4.3.2 Lift mode

General measurement procedure for lift mode: Model selection ⇒ Lift the vehicle/ push compensation ⇒ Adjust ⇒ Back tilt measurement ⇒ Adjust ⇒ Test drive ⇒ Save measurement data ⇒ View/print results, The following describes the operation flow and method of the lift mode.

Note: Before the cart is measured, the steering wheel must be level and locked with a steering wheel retainer.

Model selection



Select **【】** in the main interface of the system, the system automatically enters the vehicle selection interface, and the vehicle selection interface is as shown in the figure 4.3.2-1:



Figure 4.3.2-1 Model selection

Push compensation

After finding the model to be tested, click **【✔】** to automatically enter the cart compensation measurement interface. If the target positioning is not accurate, there will be corresponding adjustment prompts, as shown in Figure 4.3.2-2, or other prompt information, adjust the target separately. Until all prompts disappear.

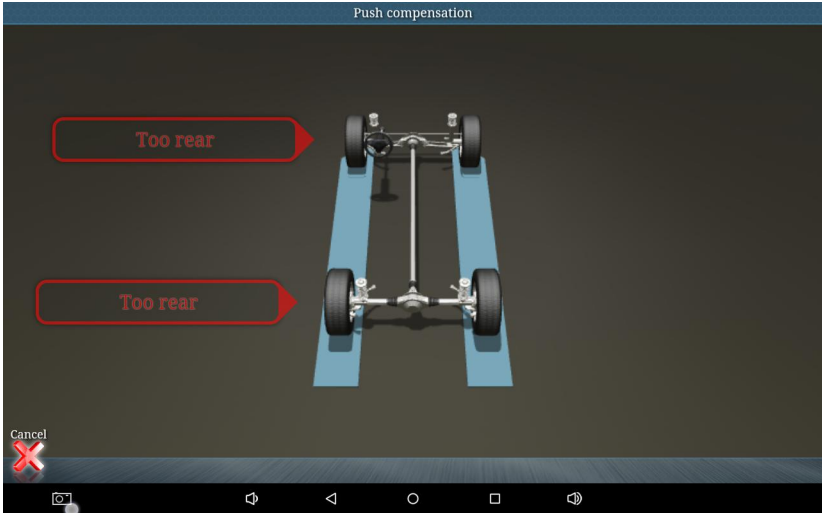

Figure 4.3.2-2 Target adjustment tips

After the adjustment is completed, the program automatically enters the cart compensation interface, as shown in Figure 4.3.2-3:

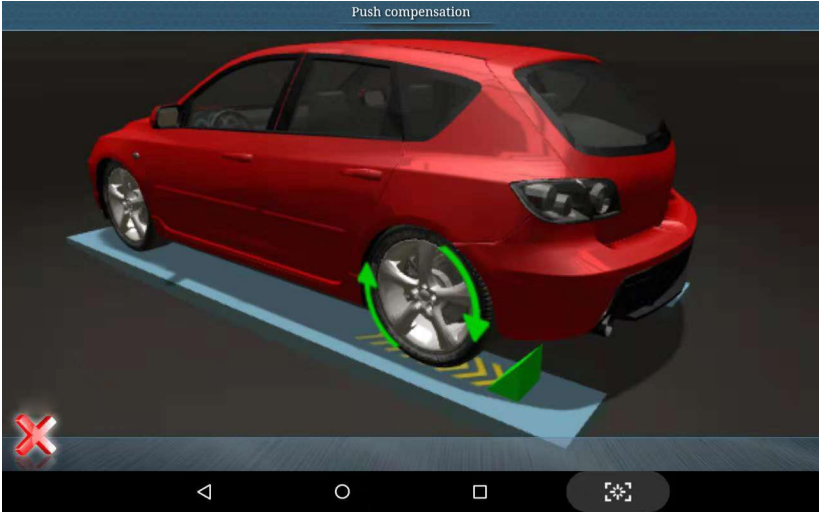
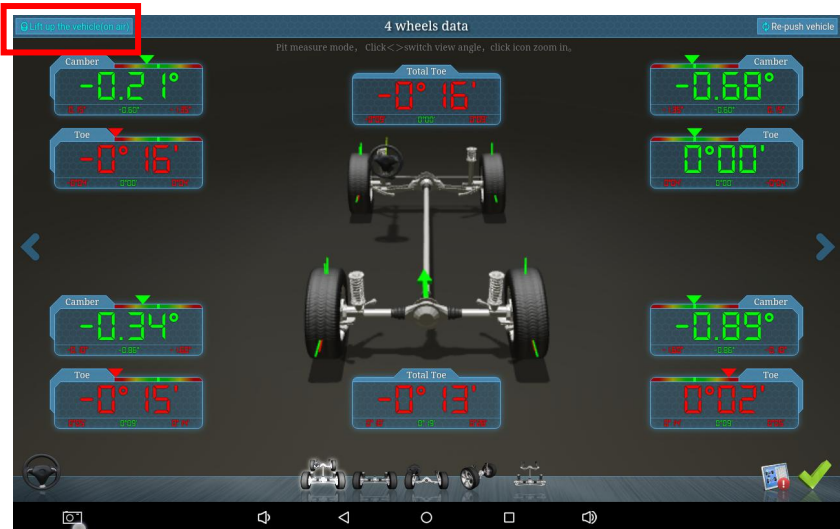

Figure 4.3.2-3 Push compensation screen

➤ **How to do push compensation**

- 1) Click Cancel **【X】** in the push compensation interface, wait for a while, and the following four rounds of data will appear, indicating that the program calculation is completed and the next step can be performed;



- 2) In the four-wheel data interface, click [lifting the body (hanging)] in the upper left corner, the software automatically switches to the lift measurement mode, and the target monitoring mode is also automatically switched. At this time, when the software pops up the following prompt, please operate the lift and Lift the body slowly;

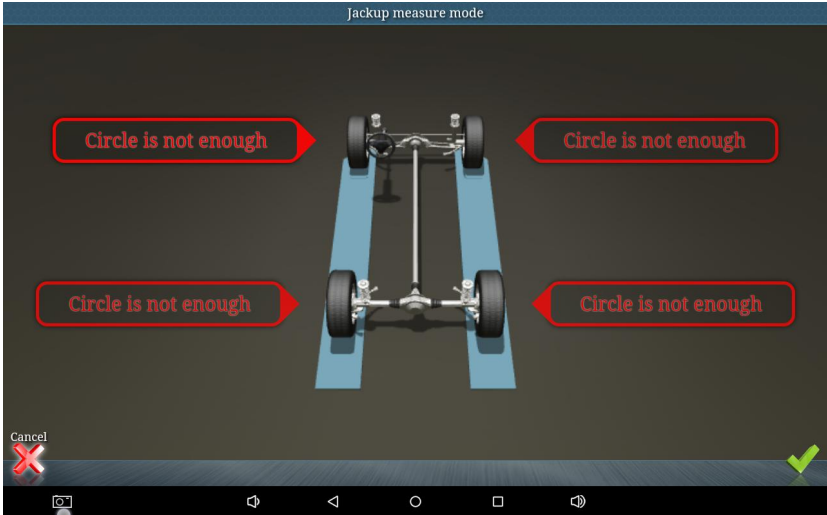

- 3) When the following prompt appears, stop lifting the body and click **【 ✓ 】** to complete the lift mode setting;

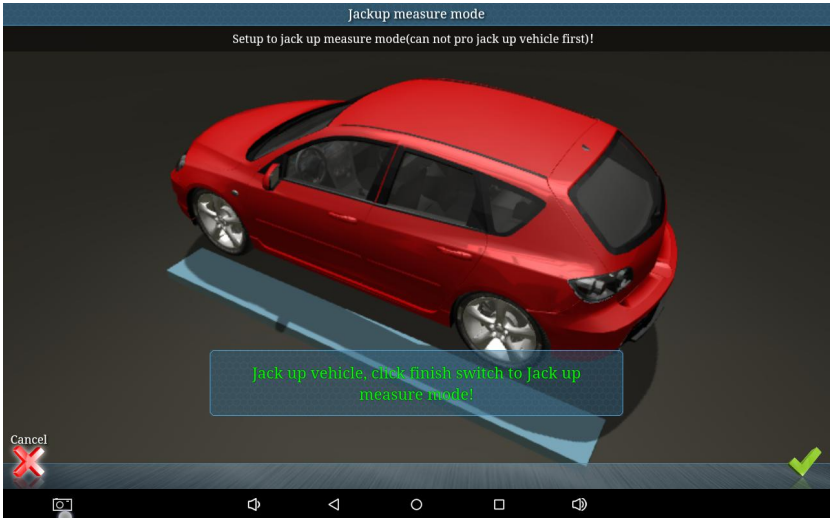

- 4) After the lifting mode is set, the software automatically returns to the four-wheel data interface in the lifting mode. As shown in the figure below, click [Re-Trolley] in the upper right corner to start the cart compensation measurement;

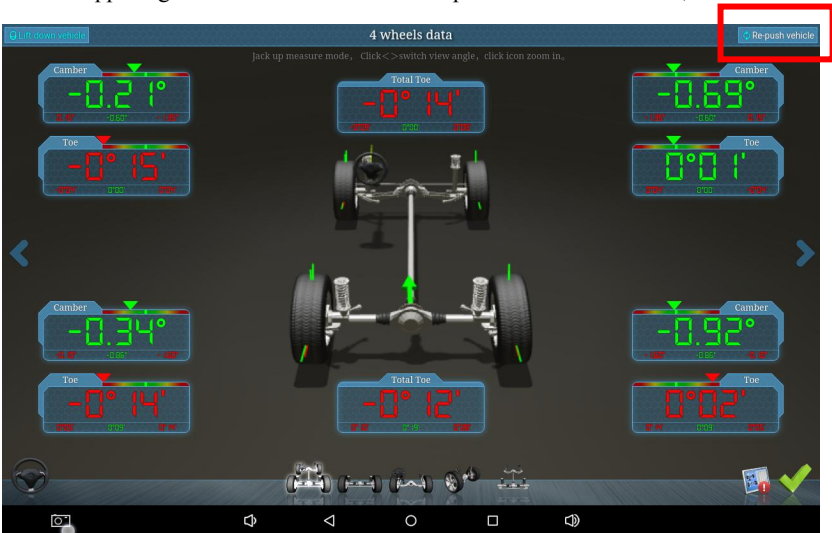

- 5) The push compensation interface is shown in Figure 1. First, slowly turn the left rear wheel backwards according to the prompt until the yellow reference line reaches the green dot position, as shown in Figure 2, stop rotating. ;

Note: Do not touch the target when turning the wheel!

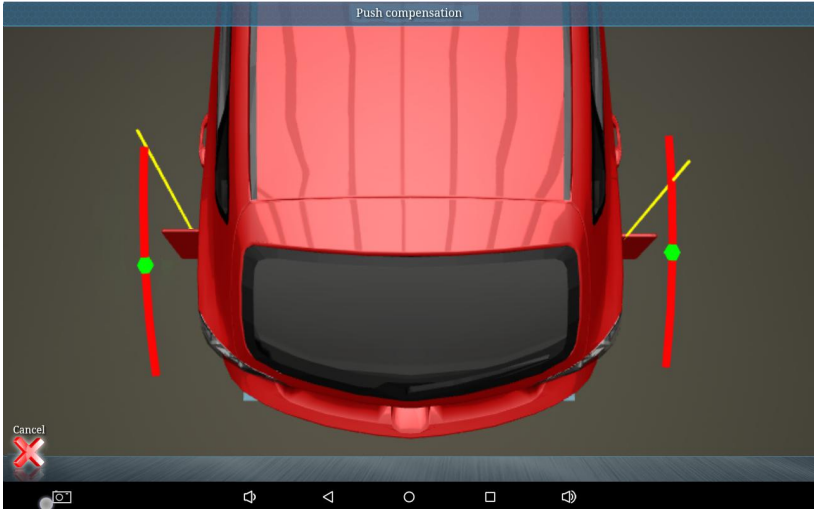

Figure 1

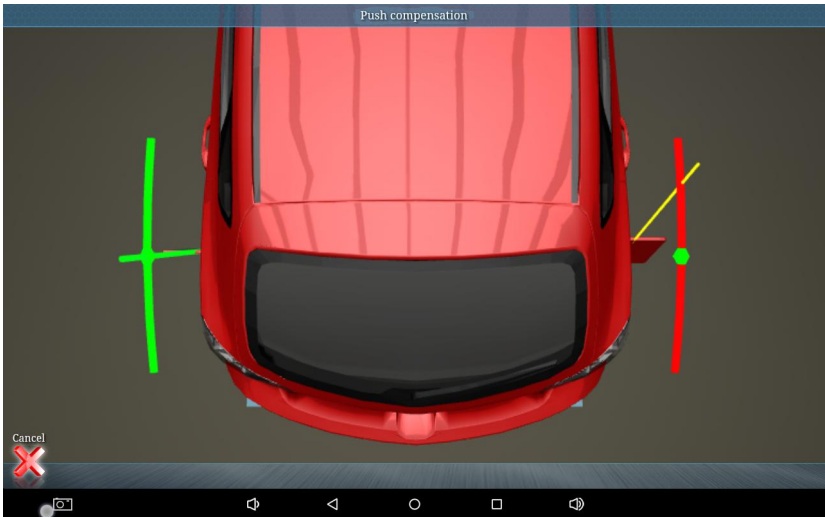
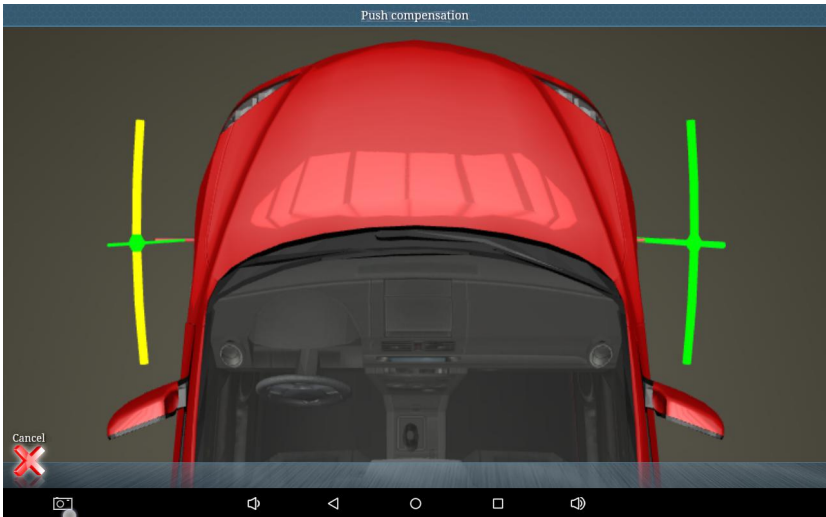
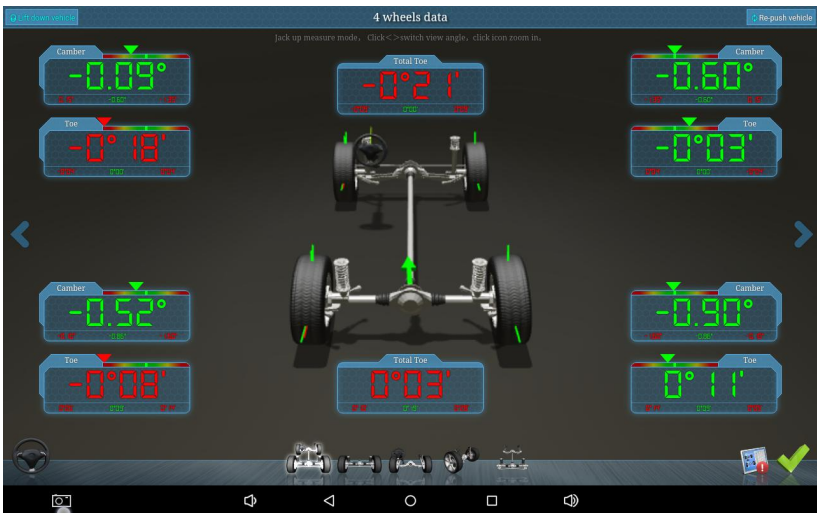

Figure 2

- 6) According to this method, the rotation is reversed: left rear wheel, right rear wheel, right front wheel, left front wheel;



- 7) The measurement is completed, and the measurement result is as shown below (the measurement data of the legend is only for operation instructions and has no reference value).



Red font: measured values are outside the standard range

Green font: measured values are within the standard range

4.4 Back tilt measurement

When measuring the backward tilt, the pneumatic handbrake must be effective, and the corner plate is installed at the center of the front wheel of the car. In order to make the wheel free to rotate, the locking pin on both sides of the corner plate must be removed.

In the cart compensation measurement result interface, select the back tilt measurement  in the lower left corner, the back tilt measurement interface is shown in Figure 4.4-1:



Figure 4.4-1 Back tilt measurement interface

Operation interface description:

- Scroll bar: the blue square will slide left and right as the steering wheel turns;
- Rotation direction prompt: prompts the operator to turn the steering wheel;
- Target status: when there is an error in the target data acquisition, there will be a

corresponding target position adjustment prompt.

Note: The handbrake must be pulled and the foot brake must be held before the rear tilt measurement and the shunting.

➤ **How to do backward tilt measurement**

- 1) Follow the instructions on the screen to first turn the steering wheel to the right (about $+8^{\circ}$ or so). When the scroll bar is close to the red area, stop turning the steering wheel;

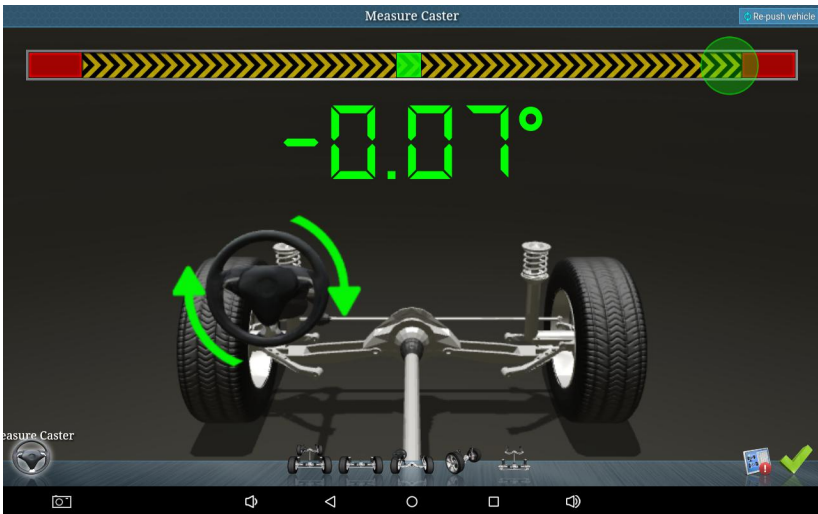

Figure 4.4-2 Right turn steering wheel

- 2) Follow the instructions on the screen and then turn the steering wheel to the left (about -8° or so). When the scroll bar is close to the red area, stop the steering wheel;

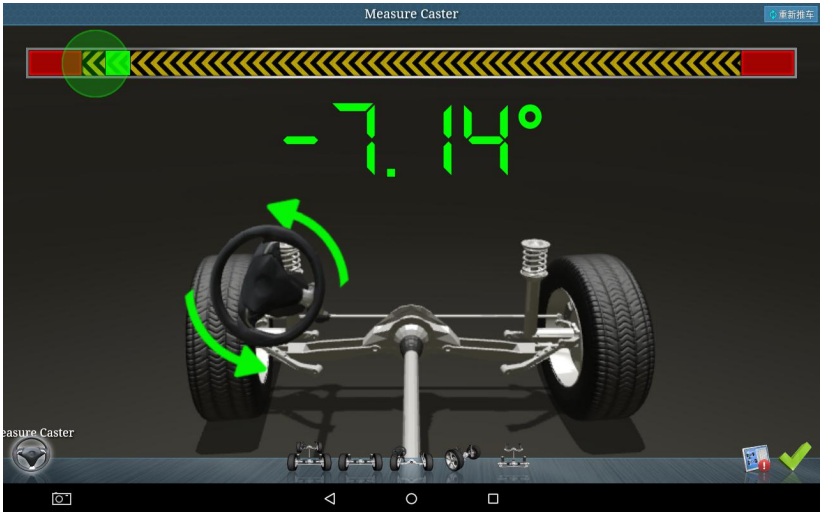

Figure 4.4-3 Left turn steering wheel

- 3) At this point, according to the prompt, slowly return to the right steering wheel (about 0° or so);



Figure 4.4-4 Back to the steering wheel

- 4) If the measurement is successful, the system will automatically pop up the measurement results, as shown in the figure:

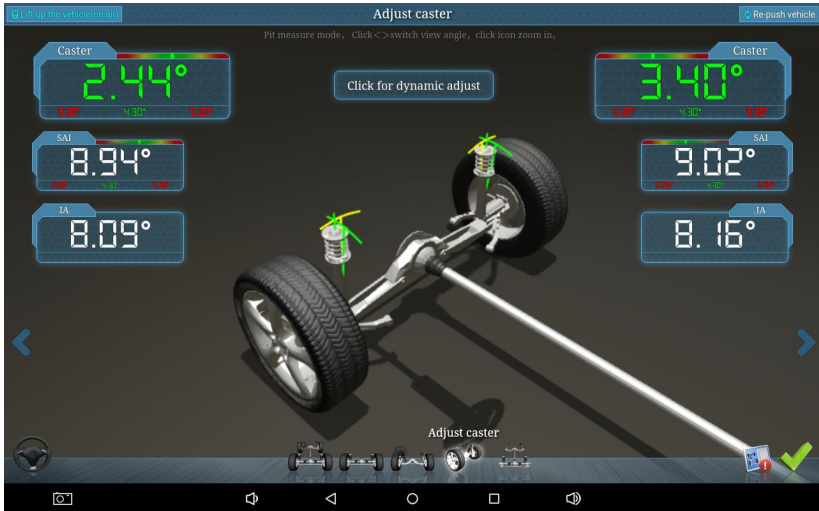

Figure 4.4-5 Measurement results

Red font: measured values are outside the standard range

Green font: measured values are within the standard range

White font: current measurement value has no reference range

4.5 Vehicle adjustment

In the measurement result interface, select [Adjust the rear wheel], [Adjust the front wheel] or [Adjust the caster] to enter the adjustment interface, as shown in figure 4.5-1:

The general adjustment order of the wheels: First the rear wheel and then the front wheel.

Rear wheel adjustment order: camber angle → toe

Front wheel adjustment order: caster angle → inclination angle → camber angle → wheelbase → toe

Note: For more general overview of wheel aligners and analysis of measurement data, please see the appendix!

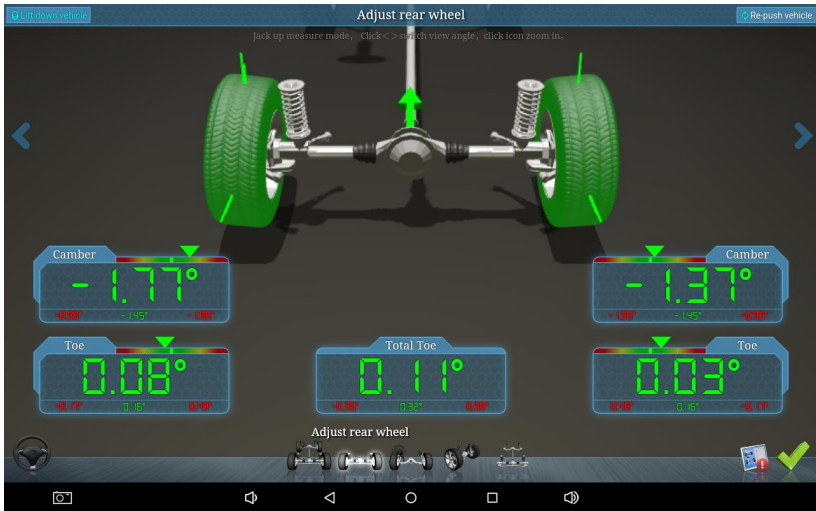

Figure 4.5-1 Adjustment interface

Attention!

If the new car or the car with good condition can be adjusted to the qualified range according to the standard data, the abnormal phenomenon can be eliminated; but the old car or the car with the aging condition can only be used as a reference.

4.6 Data saving

When you click [Exit] after completing the vehicle adjustment, the system will automatically pop up the following prompt, select [Save Data], fill in the vehicle related information on the maintenance record interface, click [OK] to save, all test records can be viewed or changed in [Maintenance Information].

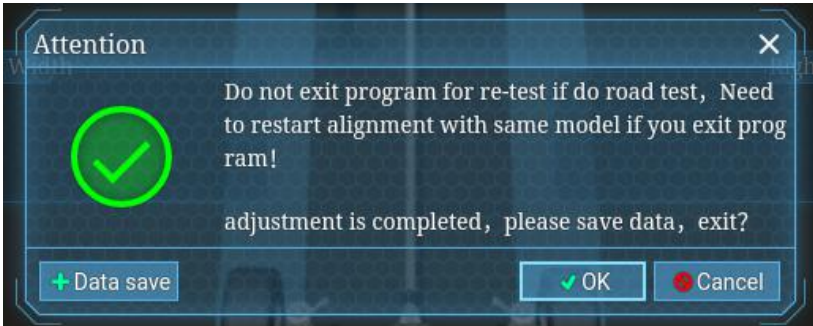

Figure 4.6-1 Data saving prompt



Figure 4.6-2 Save measurement data

4.7 Print report

To print a wheel alignment test report, users need to install the printing device by themselves.

Remarks:

This system uses the freezing point restore. Before the installation, please turn off the restore function and install under the normal mode and then reset to the restore mode

after the installation is completed. Press "Shift" + "Ctrl" + "Alt" + "F6" at the same time, password: tt. Set it as not restore, and install after restart.

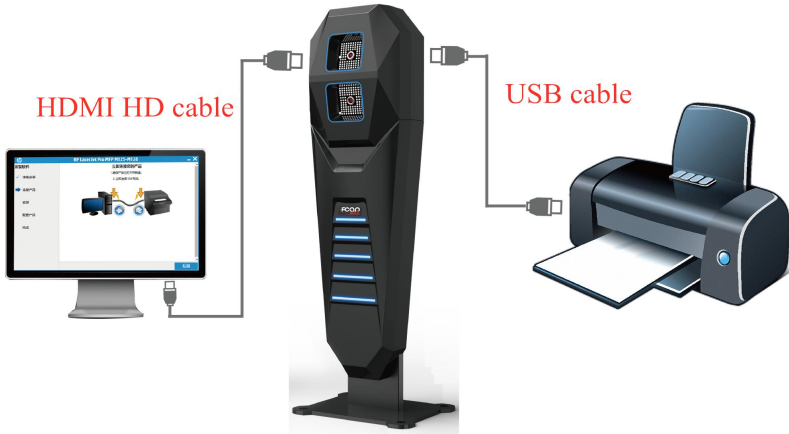
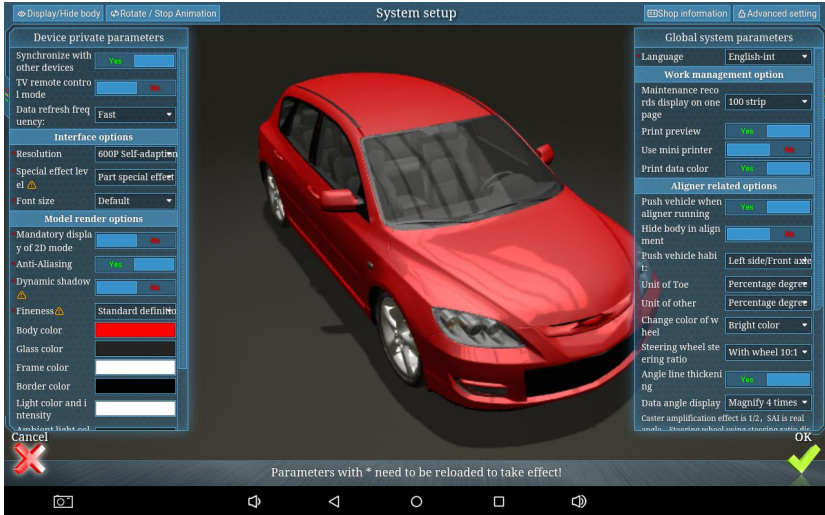

Figure 4.7-1 connect to printer

Note: Driver installation wizards vary slightly among different brands and models. Please install by referring to the manual of the printer.

5. System setting

Select [System Settings] on the main function interface for store information, language settings, synchronization settings, print settings, etc.



5.1 Advanced setting

The advanced setting include the system's precise parameter settings. Don't changed any system parameter except for selecting the target type, setting camera parameters, and setting the front position, other system parameters are not allowed to be changed at will.

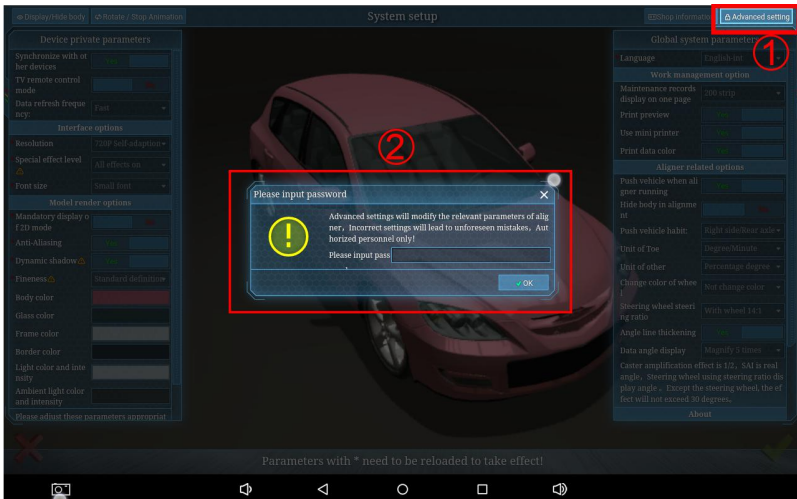

Figure 5.1-1 Enter the advanced setting

In the system settings interface, select [Advanced Setting] in the upper right corner,

enter the password SY2015, and click [OK] to enter the advanced settings, as shown in Figure 5.1-2.

Note: Don't change advanced settings without instructions professional





Figure 5.1-2 Advanced setting screen

5.1.1 Target type setting

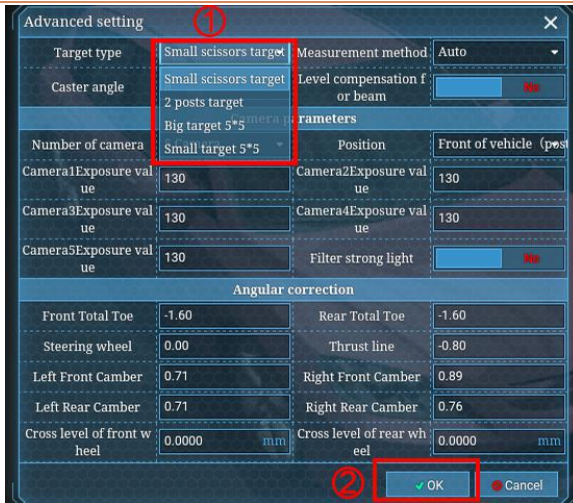
Different installation schemes, as shown in Table 1, select the corresponding target type.

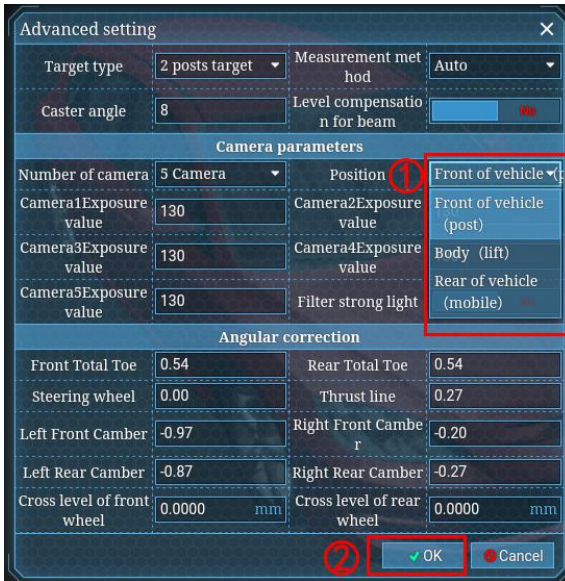

Table 1:

Target type	Physical map	Applicable platform
Target for small -scissor lift		Small scissor lift Large scissor lift
Target for 2-post lift		Two-post lift Four-post lift
Big target 5*5	Not applicable	Not applicable
Small target 5*5	Not applicable	Not applicable

Tip: For the installation plan of each platform, please refer to the “5D Four Wheel Positioning System Installation Plan” section of this manual.

5.1.2 Set the front position

The user can set the front position according to his own detection environment and detection habits. Once the front position is set, please do not change it at will.



Position mode	Description
Headstock (column)	In the ground mode, the front of the vehicle is aligned with the four-wheel alignment host.
Body (lifting machine)	In the lift mode, the front of the vehicle is aligned with the four-wheel alignment host.
Tailstock (mobile)	In the ground mode, the tail is aligned with the four-wheel alignment host



5.1.3 Set camera parameters

When the measuring environment is too dark or too bright, which is not conducive to the target to provide the target graphics reflection, the camera exposure can be adjusted. In general, the greater the exposure value, the higher the exposure, and the lower the exposure value the lower the exposure.

The actual application fields of camera 1, camera 2, camera 3, camera 4, camera 5 are shown in figures 5.1.3-1 and 5.1.3-2. Please adjust the corresponding camera exposure according to the position of the camera.

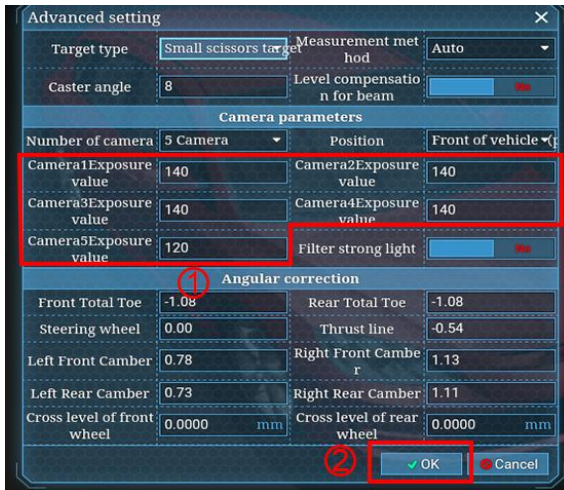

Figure 5.1.3-1 Camera exposure setting

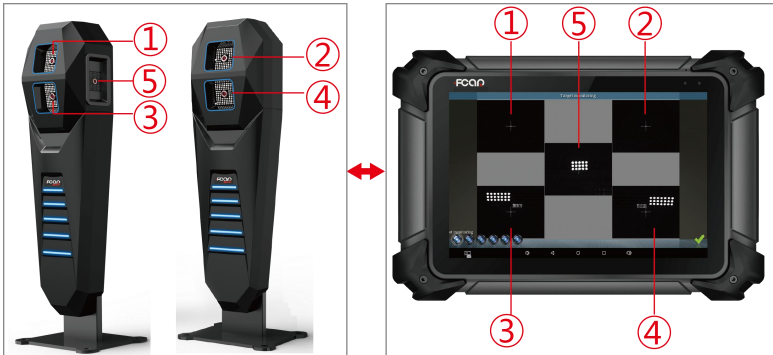

Figure 5.1.3-2 Camera corresponding position

6. Update the model library

FCAR 5D four-wheel alignment system provides standard parameter information for many models at home and abroad when the machine is shipped. In addition, it also provides a custom-added model data function, which is convenient for users to add any model information that's not in the database to better cater for specific cases.

In the [select model] interface, click [copy to self-built model library] to enter new vehicle model information and data, as shown in the following figure:



Note: Please add the model data according to the standard of factory and do not add it at will!

Contact us:

Headquarters: 8F, Chuangyi Bldg., No. 3025 Nanhai Ave., Nanshan, Shenzhen, China
518060

Factory: West 1F, Bldg. B, Hengchao Industrial Park, Tangtou North Ave., Bao'an,
Shenzhen, China 518108

Tel: 0086-755-82904730

Fax: 0086-755-83147605

E-mail: marketing@szfcar.com

Website: <http://www.fcar.com>

North America sale, service and support:

FCAR TECH USA

Tel: 443-380-0088

Email: support@fcarusa.com

Website: <http://www.fcarusa.com>

Address: 7090 Golden Ring Rd, Suite 107, Rosedale, MD 21237



Shenzhen Fcar Technology Co., Ltd.



Shenzhen Fcar Technology Co., Ltd.



Certification

This product has been strictly inspected as qualified products and met the company standards.

Product name	
Product serial number	
Date of production	
Inspector	



Warranty card

Product name	
Product serial number	
Purchase date	

Company name: _____

User address: _____

Contact person: _____

Contact number: _____

